

**PHYSICAL
INSTALLATION
PLANNING GUIDE**

BFC 5001

BASIC/FOUR and  are registered trademarks
of BASIC/FOUR CORPORATION

COPYRIGHT 1977 © by BASIC/FOUR CORPORATION. All rights reserved.

basic / four corporation
an MAI company

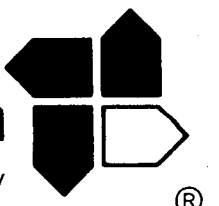

All specifications are subject to change without notice.

Foreword

This publication contains information about the physical installation of a BASIC/FOUR system. It includes information about space requirements and site selection, and a brief description of the BASIC/FOUR units and their layouts (floor plans), with explanations of electrical and environmental requirements.

Since innumerable variables are involved in an installation, Basic/Four Corporation cannot assume responsibility for installation planning based on this publication. However, in the majority of cases, installation planning is a simple straightforward procedure. Reasonable assistance beyond the scope of the manual will be provided upon request.

Table of Contents

TITLE	PAGE	DATE
Introduction 3	6/14/76
Site Selection 4	6/14/76
Environmental Control5,6	6/14/76
Electrical Requirements7,8	6/14/76
Site Layout and Preparation9-11	6/14/76
Site Planning Grid12	6/14/76
Equipment Line Drawings13	6/14/76
Typical Floor Plans14	6/14/76
Preinstallation Checklist15	6/14/76
Central Processor Cabinet17	6/14/76
Disc Memory Cabinet18	6/14/76
Video Display Terminal Model 7220/723019	6/14/76
VDT Desk20	6/14/76
Executive Display Terminal21	6/14/76
Serial Printer22	6/14/76
300 LPM Printer Model 350023	6/14/76
600 LPM Printer Model 360024	6/14/76
Punched Card Reader25	6/14/76
Magnetic Tape Unit26	6/14/76
Paper Tape Punch27	6/14/76
Paper Tape Reader28	6/14/76

Introduction

Your BASIC/FOUR equipment will be arriving soon and there are several requirements you should be aware of to insure a proper installation. Not only must adequate space be allocated for operation and maintenance, but space should also be provided for future growth or unforeseen system related activities. The space allocated should preferably be located adjacent to using activities such as the accounting department. With proper planning, you can design a facility that is attractive as well as efficient. A neat layout will help promote employee efficiency and will have a positive effect on any of your customers that see the operation.

Perhaps you're thinking that planning the installation requires engineering expertise beyond your capabilities. Or on the other hand, you may believe that all that must be done is to find an empty room while awaiting the arrival of the installation team. Neither extreme is true. You can plan the job but it will take time and some advice from the experts. The importance of preinstallation planning should

not be deemphasized as it may affect overall operating costs and will obviate very expensive post-delivery system or facility changes. Poor planning can result in extended periods of total system inoperation in extreme cases.

In general, the BASIC/FOUR system can operate problem-free in any area suitable for *comfortable* human habitation. If the environment is too hot, too cold, too damp or too dry for the average employee, corrective measures will probably be required. Furthermore, if the installation is to be made in a fairly new building, the electrical requirements can usually be met with existing power circuits. Older buildings with obsolete power circuits or lines shared with other electrical equipment (including adding machines) may require changes to the building's electrical wiring and/or relocation of equipment that may produce electrical noise. These and other more subtle factors associated with installation are described in the following text. A preinstallation checklist is included to help you with your planning activity.

DATE 6/14/76	TITLE Installation Planning Guide	PAGE 3
-----------------	--------------------------------------	-----------

Site Selection

Under ideal circumstances, the BASIC/FOUR system you have ordered is to be installed in a spacious, air-conditioned building having adequate power outlets and no problems with either work flow or electrical noise from nearby equipment or machinery. However, yours is likely to be a typical installation where ongoing activities seem to restrict the installation to a room or space of apparently sufficient size. You must determine if the initially selected area is suitable or if some disruption of company activities is necessary to reduce the total cost of system installation. A comparative study of costs in two or more locations requires the definition and documentation of all cost factors associated with each location, if only to satisfy your own desire for efficiency. In many cases the advantages of a secondary location may become quite evident during the planning stage. For example, the initially selected area may be too small or may require the purchase of an air conditioner as well as a complete revamping of electrical wiring, whereas the relocation of one or two departments may make available an adequately sized location requiring no air conditioning and no rework of electrical wiring.

Most costs involved in the above example can be defined. However, the relocation of any department will alter interdepartment communications paths and thus may incur indirect costs over a period of time. In such cases, it is very difficult to determine precise costs but experienced supervisory personnel can provide a good idea of any loss of communications between departments and any additional employee work that will be engendered by the relocation. This analysis must take into account that the installed system may drastically simplify interdepartment communi-

cations and eliminate close person-to-person ties that formerly existed. In many applications, the computer system may be viewed as an information center through which many interdepartment communications occur.

The physical location of the BASIC/FOUR system should be established based on the interplay between the system and interfacing departments such as accounting, shipping, receiving, etc. However, the economics of installation may indicate a less than ideal location with respect to the work flow. This may pose no problem if it is recognized that few departments require physical access to the system and that most intercourse with the system will be via easily transported forms and reports. Furthermore, it may be desirable to restrict access to the system area to safeguard sensitive data (payroll, etc.). However, persons operating the system or those controlling system use should have their desks nearby.

In view of the above, it can be seen that site selection may be a complex procedure and that both physical and managerial considerations may be important. Also, new criteria may present themselves during the planning stage. It is recommended that plans be generated for system installation in more than one location to allow comparison and permit changes. The plans should include detailed layouts together with data on managerial as well as physical considerations. This guide outlines methods for collecting data concerning the physical installation but in the final analysis you must weigh the definable costs of the physical installation against the more subtle effects of employee efficiency, customer relations, etc.

PAGE 4	TITLE Installation Planning Guide	DATE 6/14/76
------------------	---	------------------------

Environmental Control

Three factors of environment to be considered during installation planning are temperature, humidity and airborne dust. In each case, the conditions existing in the average office are adequate for the system. Allowable and recommended ranges for temperature and relative humidity are as follows:

	Allowable		Recommended	
	Low	High	Low	High
Temperature	60°F	90°F	70°F	80°F
Humidity	20%	85%	40%	60%

Temperature control is perhaps the most important environmental factor because the outside temperature of almost any city deviates from the allowable limits. Low temperatures are of little concern because very few offices are without a thermostatically controlled heating device; however, high temperatures may be a problem. Cooling of the system should be considered prior to installation. Assuming a closed room with or without air conditioning, the following factors determine the ambient temperature within the room:

- The maximum outside temperature and/or temperature of adjacent inside areas.
- The heat contributed by the units comprising the BASIC/FOUR system (BTU values are provided within this guide).
- The heat contributed by other equipment within the room (approx. 3.4 BTU per watt).
- The body heat of individuals that will use the room (approx. 400 BTU per person).
- The areas and insulation qualities of the walls, ceiling and floor.
- The temperature and volume of ventilating air.

If the outside temperature is not too high, adequate ventilation of the room with outside air will provide satisfactory cooling. If the outside temperature exceeds 90° F, the above factors may be used by a reputable air conditioning specialist to determine if air conditioning is required or

if current air conditioning is adequate. For installations where an existing air conditioning system is to be used, air flow must be rebalanced to insure proper cooling.

One important factor affecting cooling is the amount of glass in exterior walls of the room. A wall of glass has very poor insulating qualities compared to a wall of insulated brick and provides almost no insulation against radiant energy from direct sunlight. If a large glass area cannot be shaded, it is recommended that the glass be coated with one of the commercially available glass tinting films or solutions that block the heat producing infrared rays while permitting near normal vision. Drapes are also beneficial when they are opaque enough to prevent penetration of direct sunlight.

CAUTION

If an air conditioner is to be installed, special care should be taken to insure that the installed unit will not create electrical noise. The use of a separate power line is mandatory and special filtering may be necessary for some air conditioning units. Advise your air conditioning specialist of the unacceptability of units creating excessive electrical noise.

Humidity, at high and low extremes, will impair handling of paper documents, cards, etc. Low humidity increases the probability of uncomfortable static discharges which, under extreme conditions, may affect equipment operation. The installation of certain types of carpeting tends to increase static electric charges. Carpeting is discussed in the Site Layout and Preparation section of this guide.

Paper stock (especially cards) at extreme high humidity levels is hard to handle and may cause improper machine feeding. If paper is stored in an area of high humidity and then used in the system in an area of lower humidity, warpage may occur. This is the most common cause of improper feeding of punched cards. With extremely low humidity, sheets of paper (or cards) attain a static charge which again interferes with handling and machine feeding.

Many air conditioners control humidity by overcooling the air to remove moisture, then adding heat to gain the desired environmental conditions. As air is cooled, relative humidity rises to 100 percent, after which condensation occurs. The normal heat rise in air conditioning ducts reduces the relative humidity, but artificial heating may be

used to achieve adequate reduction. Thus the air conditioner must have a reserve cooling capacity to control humidity at high temperatures (most air conditioners are rated for their ability to remove moisture as well as their ability to cool). To control excessive humidity where air conditioning is not required, it may be necessary to employ a dehumidifier.

Evaporative air conditioners, normally used only in dry desert areas, provide cooling by adding moisture to the air stream. These air conditioners are not recommended for use with the BASIC/FOUR system as humidity may often approach 100 percent. Consult your air conditioning specialist if this type of air conditioner is currently installed in your facility.

Airborne dust or dirt particles may cause equipment problems if they are present in excessive amounts. If a film of dust or dirt accumulates on surfaces overnight, unnecessary wear of mechanical parts may occur and electronic components may eventually become shorted (especially with high humidity). Air conditioners, heating units, and ventilating systems should be equipped with air filters and these filters should be cleaned or replaced periodically. Electrostatic filters remove even the finest particles from an air stream. If a dust or dirt accumulation problem cannot be resolved, all equipment should remain covered with fire resistant cloth or plastic when not in use.

PAGE 6	TITLE Installation Planning Guide	DATE 6/14/76
------------------	--	------------------------

Electrical Requirements

BASIC/FOUR systems require 60 cycle, 115 VAC $\pm 10\%$ power fused for 20 amperes (or 50 cycle, 230 VAC $\pm 10\%$ at 15 amps). The required 3-wire line is usually available in any office. However, an additional requirement is that the line must be regulated to within 3 percent (the voltage change between no-load and full-load conditions). Since the full-load is determined by all devices connected to the line, it is recommended that the system have a separate line with wiring of sufficient capacity to prevent an excessive voltage drop when drawing 20 amperes. Under normal circumstances, a suitable line will be available but you must ensure that the line has no other users.

Normally each line is fused by a circuit breaker (i.e., a switch that trips off when the current through the switch exceeds its rated capacity). To determine which circuit breaker controls a line, plug a lamp into a wall receptacle that is to be used by the system and turn each circuit breaker off one at a time. When the lamp goes off, note the number imprinted on the circuit breaker. This number indicates the amperage rating of the circuit breaker. Then with this and no other circuit breaker in the off position, determine by means of the lamp, which wall sockets are controlled by the circuit breaker (ceiling lamps and other outlets may also be affected). If the circuit breaker is rated at 20 amperes and if no other equipment is on the line serviced by the circuit breaker, the line is probably adequate. However, it is possible that the wiring to the receptacle(s) is of insufficient size or that noise is introduced from other lines.

Depending on the configuration of your BASIC/FOUR system, the use of a single 20 ampere line may be insufficient. Total system power requirements (in amperes) may be determined by adding the power consumption values for each of the equipments and dividing this total volt ampere value by 115. (The equipment specifications at the rear of this manual provide power consumption values in volt amperes.) If the resultant system value approaches 20 amperes, some difficulty may be experienced due to surge currents. The largest surge current is associated with the disc drives. Most circuit breakers will accept this surge current without being tripped.

It is advisable to determine if the computer area is supplied with adequately regulated AC power. Upon request, many power companies will install test equipment to determine the need for additional line regulation. Testing

may also be accomplished by an electrical specialist using a line transient recorder.

If the line voltage varies more than 10 percent from the rated line voltage over a period of several days, corrective action must be taken. If new electrical lines are to be installed, make sure that a sufficient number of outlets are incorporated. Each unit of the BASIC/FOUR system is individually plugged into a standard 3-wire wall receptacle and a sufficient number of unused receptacles should be included to provide for future additions to the system and for maintenance equipment. If existing lines are to be used but the receptacles are too few in number or are improperly located, 3-wire extension cords of sufficient capacity may be employed. The use of extension cords is further discussed under the Site Layout and Preparation section of this guide.

The utility lines from the street can usually be expected to maintain the voltage, *on the average*, within 10 percent of the rated line voltage. Experience has shown that from moment to moment there may be considerable variation on the line due to a number of external factors not controllable by the user. Locally the house AC may have to contend with AC line transients (voltage dip) due to intermittent heavy loads such as air conditioner, heaters, elevators and others. Fluorescent light flicker and/or light dimming is normally an indication of this type of transient. Another less detectable condition is due to high frequency transients such as high voltage spikes (line noise) caused by arc welders, electric accounting machines, tool motors and the like.

Variation in the house AC can be classified into three types of disturbances for a typical business machines installation: (1) undervoltage, (2) oscillatory-decaying, and (3) voltage spikes.

The first type of disturbance is the undervoltage disturbance in which the AC voltage decreases as much as 20 percent of the rated line voltage amplitude for a duration up to 900 cycles. The second type of disturbance is the oscillatory-decaying disturbance which super-imposes an oscillatory-decaying voltage amplitude as much as 30 percent of the rated voltage with a frequency range from 400 hertz to five kilohertz, and the duration of the transient lasting less than one cycle. The third type of disturbance is the voltage spike disturbance which super-imposes a transient voltage spike as much as 50 percent of the rated voltage for a duration less than 250 microseconds.

DATE	TITLE	PAGE
6/14/76	Installation Planning Guide	7

Line transients or noise, of themselves, may cause system malfunction and can certainly be a contributory cause when coupled with extreme voltage variations and Brown-out (reduced line voltage) conditions. To ensure the best operation of the BASIC/FOUR system, a separate, or "clean", line from the building AC distribution panel is recommended. This isolated line, while desirable, is not always attainable and in any case cannot contend with the Brown-out condition where a utility company has reduced its output voltage by up to 10 percent. Reduced voltage on the AC line due to Brown-out as well as the common transient conditions described, can create problems outside of the designed tolerance of the system.

The next best alternative to a clean line is a line conditioner. The device, as the name implies, is a means of correcting those conditions (line and load transients, noise, and Brown-out) that may create system problems. A line conditioner provides isolation from line noise and line voltage variation (transients). It is designed to plug into the AC outlets designated for the system. The system then

receives its power from the outlets on the line conditioner. It requires no attention after installation.

The device contains specially designed transformers that electrically isolate the system from the raw (unconditioned) line and provide tight ($\pm 3\%$) regulation of the output voltage to the system. The unit will operate over a wide range of input line voltages (95 volts to 135 volts) and handle load variations from 0 to 300 percent of normal load. The latter requirement is needed due to the high power demands of some of the system components when the system is first powered-up and the disc drives are brought to ready. However, the line conditioner cannot compensate for an AC line that does not have sufficient capacity to operate the equipment connected to it, nor can it make up for voltage drop-out (an interruption of power).

The BASIC/FOUR Model 1950 Line Conditioner is specifically designed to optimize the operation of the system by insuring stable, noise-free power over a wide range of line voltage extremes. Contact your local sales office for additional information.

PAGE 8	TITLE Installation Planning Guide	DATE 6/14/76
-----------	--------------------------------------	-----------------

Site Layout and Preparation

A site for installation of the BASIC/FOUR system will normally be selected on the basis of utility and the ease with which adequate power and environmental control can be implemented. Other factors that affect site selection are the size and, in some cases, the shape of the available area. In reality, a site must be selected and laid out as early as possible because cables of special lengths must be ordered well in advance of the system shipping date. The cable lengths listed in the equipment specifications may appear more than sufficient, especially if the equipment is to be clustered. However, in some cases desks used as work stations may be interspaced between terminals or components of the system may be separated. In any case, site layout based on a systems approach to computer usage should be established at an early date.

Assuming that site location, power circuits and environmental control are suitable, factors to be considered during site layout and preparation include:

- Fire prevention
- Layout of equipment and furniture
- Location and containment of cabling
- Location of air conditioning equipment (if required)
- Storage of materials, supplies and records
- Use and selection of carpeting
- Telephones
- Equipment weight

FIRE PREVENTION

Fire prevention measures should be reviewed and implemented prior to system installation, not only to protect your investment in the system but also to satisfy local fire prevention regulations and insurance carrier requirements. Perhaps the best source of information on this matter is your insurance agent who can inform you of local regulations and can advise you of any possible insurance premium savings accrued by improved fire prevention measures. All equipment and systems manufactured by Basic/Four Corporation are submitted for complete testing by Underwriter Laboratories and the City of Los Angeles for code approval.

If local regulations or your insurance requires a fire suppression system, any costs involved should be determined at an early date and used as a factor in establishing

site selection. If a sprinkler system is installed or is to be installed, it is recommended that the system be a pre-action sprinkler system. With the latter system, water is introduced to the overhead piping only when high temperatures activate a heat-sensitive device so the system area will not be flooded if a sprinkler head is inadvertently broken.

One of the most effective fire extinguishing systems available today utilizes Halon 1301* as a fire suppression agent. Halon is quick acting, low in toxicity and does not damage electrical components.

Whether or not a fire suppression system is installed, it is recommended (and usually required) that an adequate number of portable carbon-dioxide fire extinguishers be located in and/or near the installation site. The extinguishers are usually best located adjacent to entrances to the computer room. Your local fire department can advise you of the number of extinguishers required and the best locations for them. Attention should also be given to protection of storage areas from fire.

LAYOUT

If you have read the preceding sections, you know that many factors must be considered before selecting work areas for operating personnel. You cannot indiscriminately reposition a computer work station (or the system) as you can a desk or even an accounting machine. Planning must consider all the aforementioned factors if an efficient and viable computer-based business system is to be implemented.

Operational requirements should determine the specific location of the various components in the computer area. Because the separate components are connected by cables of restricted length, and because of space limitations and the necessity for maintaining clearances between machines for servicing, work space, and aisles, you may need to prepare and analyze several tentative layouts before deciding on the one best suited to your needs.

Within this guide you will find an 8½ by 11 inch (21.59 by 27.94 centimeter) Site Planning Grid and a page of line drawings representing the BASIC/FOUR equipment and their associated work and service areas. The scale used for both the grid and the line drawings is 3/16 inch = 1 foot (4.762 millimeters = 30.4 centimeters). To plan your layout make a photocopy of the grid and the equipment line drawings, draw the outline of your computer room on the reproduction of the grid, cut out the reproduced equipment line drawings, and paste the cut outs on the grid when a desired layout is established. Repeat this process for layout variations and for alternate installation sites.

*Halon 1301 is manufactured by Dupont.

DATE	TITLE	PAGE
6/14/76	Installation Planning Guide	9

Note that cutouts are not provided for peripherals that are not free standing (the paper tape units, the Card Reader, and the Magnetic Tape Unit). Each of these peripherals may be mounted on either a VDT desk (purchased for this purpose) or a standard office desk. One half desk is required for each non free standing unit. Note also that the work area and service area of each equipment are identified on the line drawings. Service areas of adjacent units may overlap to conserve space in the computer area, but under no circumstances should a work area be less than indicated by the cutout (if possible allow one additional foot of depth for desk work areas). The arrangement should allow for an 18 inch aisle to the rear of each free standing equipment to permit servicing.

The layout plan you prepare should include space for desks, storage and file cabinets, environmental control equipment, and future growth. For this purpose you must prepare your own cutouts based on a 3/16 inch to 1 foot (4.762 millimeters to 30.4 centimeters) scale. The office desk cutout provided is for a 30 by 60 inch desk (76.20 by 152.40 centimeters) that may or may not be available to you.

One very important factor to be considered when preparing a layout floor plan is the location and angular position of each piece of equipment relative to light sources (especially large windows). Office desks and most equipment of the system should receive relatively high light intensity to permit reading of printed material, identification of controls, and performance of operator activities such as magnetic tape loading, paper feeding, etc. Optimum use of the VDT requires a light intensity sufficiently low to allow easy reading of the VDT display. If the VDT operator is facing a high intensity light source or a window receiving direct sunlight she (or he) may experience difficulty in reading the display. A similar difficulty also occurs if the VDT screen is bathed in light from any high intensity light source. The VDT should preferably be in a semi-darkened area and should be at a right angle to windows and any major source of artificial light. Ideally, the immediate area of the VDT should be illuminated by lighting whose intensity is adjusted by the operator.

We've included two examples of typical office installations to serve as models for your planning. The models should be of some help, although we recognize that every office setup has its own variations. The second model illustrates the positioning of VDTs in a room containing two exterior walls of glass.

CAUTION

Careful planning of the original layout will prevent costly moves at a later time. The equipment should be moved only by a qualified service representative. Improper handling of equipment may cause damage, especially to the surface of the discs.

CABLING

In general, each equipment is supplied with one power cable terminated with a 3-wire connector and one signal cable which is terminated at the C.P.U.

Because the cables are small in size and few in number, the expensive raised floors required with most computer systems are not required. To increase the safety and attractiveness of an installation, plastic troughs to house the cables may be purchased inexpensively from an electric supply store. The troughs come in six-foot lengths and are of sufficient width and depth to house power cables as well as interequipment signal cables.

NOTE

Cables supplied with the system will have the lengths indicated in the equipment specifications within this manual. Terminal signal cable extensions of up to 1000 feet (304.8 meters) may be obtained if ordered at least 90 days prior to system shipment. Local printer signal cables cannot be extended.

Since the power cables supplied with each piece of equipment are permanently wired to the equipment (except the CPU) and are of fixed length, it is necessary to have a power receptacle within a few feet of each unit. If wall receptacles are too far from the equipment or are of insufficient number, extension cables of adequate capacity may be inserted within the troughs. Each extension cable should provide either two or four receptacles, depending on the equipment arrangements, the amperage rating of the equipment to be plugged in, and the current capacity of the extension cable. In general, the wire size of the extension cable should be greater than is necessary to prevent any perceptible voltage drop.

Routing of the cables or positioning of the troughs should be such that all work positions may be reached without the necessity of stepping over a cable or trough. In most instances, this means that the troughs should be positioned adjacent and parallel to a wall. However, a trough may be used to supply a string of equipment down the center of a room if the equipment and/or furniture is positioned to prevent walking over the troughs (i.e. operator access from one side of the equipment only).

Please be aware that neither Basic/Four Corporation nor SORBUS personnel are authorized to act as electricians. Specifically, this means that BFC and SORBUS representatives may not install cables other than connecting them to BASIC/FOUR equipment. Any special requirements (such as running cables through walls and over doorways) must be performed by a licensed electrician.

In addition, Basic/Four Corporation recommends that you do not connect, disconnect or move BASIC/FOUR equipment. If damages occur as a result of these actions, they are not covered by any warranty or SORBUS maintenance contract.

PAGE 10	TITLE Installation Planning Guide	DATE 6/14/76
------------	--------------------------------------	-----------------

If you decide to move your BASIC/FOUR equipment, please contact your local SORBUS representative to assist you. The actual movement of the equipment will not be performed by either SORBUS or Basic/Four Corporation. However, the proper preparation and packing of your equipment by SORBUS could eliminate repair charges and down time.

AIR CONDITIONING

Under ideal conditions, air conditioning and other types of environmental control equipment will be located outside the computer area. This will reduce the acoustical noise level in the room and will reduce the chances of electrical interference. In any event, the environmental control equipment must not be connected to the line providing power to the computer system. If environmental control equipment must be located within the room, allow sufficient space for proper operation and servicing (filter replacement, etc.).

STORAGE

Storage requirements will vary greatly depending on the equipment comprising the BASIC/FOUR system and the applications of the system. The system will almost certainly require storage of paper forms and disc packs. Also, storage will be required for magnetic tape and/or paper tape if the associated equipment is included in the system. Temporary storage will be required for punched cards if data is initially provided from this source. With regard to paper forms, storage will probably be required for both bulk supplies and system produced records. In most cases, storage requirements will increase with time so it is therefore necessary to allocate ample space. Combustible material and supplies should be in metal cabinets or fire resistant containers in accordance with the National Fire Protection Association standard.

NOTE

Technical manuals supplied with the system require a storage area of 13 by 13 by 18 inches (33.02 by 33.02 by 45.72 centimeters) in a locked fire resistant cabinet or container. The manuals must be immediately available to servicemen and must be protected from damage or theft.

It is possible, and may be necessary, to provide remote storage for bulk items. Any remote area should be protected against damage from fire as outlined elsewhere in this guide. The remote storage area should also be free of excessive heat and humidity which could damage disc cartridges and magnetic tape and warp paper items. (Disc cartridges may be damaged at temperatures above 150°F (63.8°C) or relative humidity above 85 percent).

If humidity cannot be controlled in the remote storage area, paper items should be allowed time to stabilize within the computer room prior to use.

CAUTION

Excessive storage of bulk flammable materials in the computer room is considered a safety hazard.

CARPETING

If you plan to carpet your computer area, be sure that the carpeting you choose is a nonstatic variety (wool carpeting is the worst offender). Static problems can be minimized by the installation of carpet containing Brunslon fiber. In cases of existing carpet, if it is not nonstatic, it should be treated by spraying it with a nonstatic fluid. The carpets should be cleaned before being sprayed. The following are some of the brands that are available: AS/20 Anti-Static Agent from Wallerstein Company, 6301 Lincoln, Morton Grove, Illinois; Bigelow Anti-Shock Spray from Bigelow-Sanford, Inc., 140 Madison Ave., New York City; Carbona Stop-Shock from Carbona Product Company, 30-50 Greenpoint Ave., Long Island City, New York. Or, consult the yellow pages of your telephone directory for a carpet repair company that will do the work for you. The area will have to be resprayed at least every three months in order to maintain a static-free environment.

TELEPHONES

If telephones are to be installed in the computer area it is best that the installation be accomplished prior to system installation.

EQUIPMENT WEIGHT

All of the equipment comprising your BASIC/FOUR system is relatively light-weight compared with earlier generations of computer systems. In most installations the heaviest unit is the CPU which weighs only 535 pounds (243.2 kilograms) with two drives installed and results in an average load of 100 pounds per square foot (.18 kilograms per square centimeter). Therefore, you normally need not concern yourself with floor loading unless yours is an older or poorly constructed building. However, the CPU leveling feet when screwed down impose a load of approximately 125 pounds per square inch (17.9 kilograms per square centimeter) and may damage softer floor surfaces unless the load is distributed over larger areas by means of metal plates, etc. If you have any doubt about your building's structural integrity, consult your local (city or county) building department.

DATE	TITLE	PAGE
6/14/76	Installation Planning Guide	11

Site Planning Grid

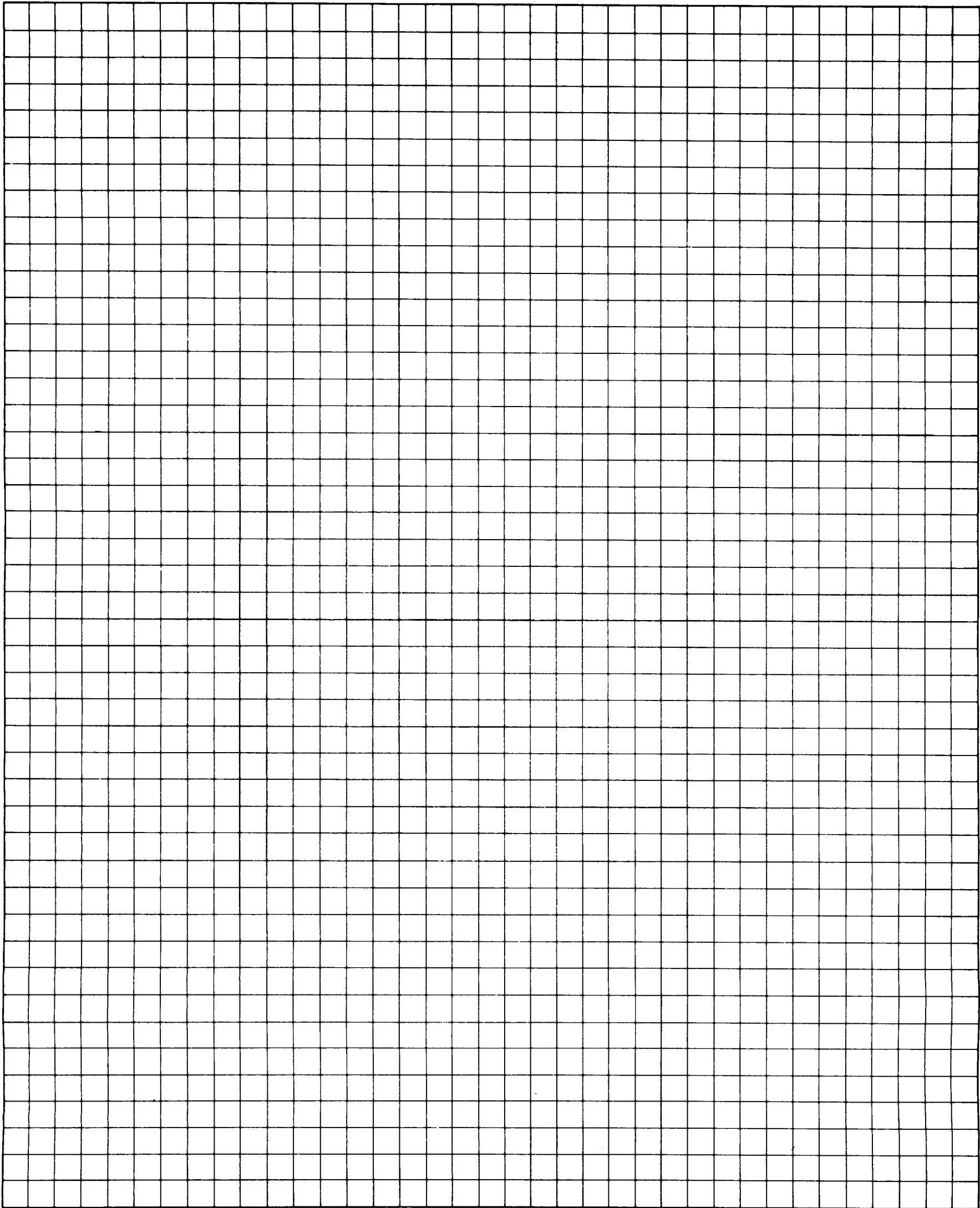



Scale: 3/16 in. = 1 ft.
Scale: 4.762 millimeters = 30.4 centimeters

PAGE 12	TITLE Installation Planning Guide	DATE 6/14/76
------------	--------------------------------------	-----------------

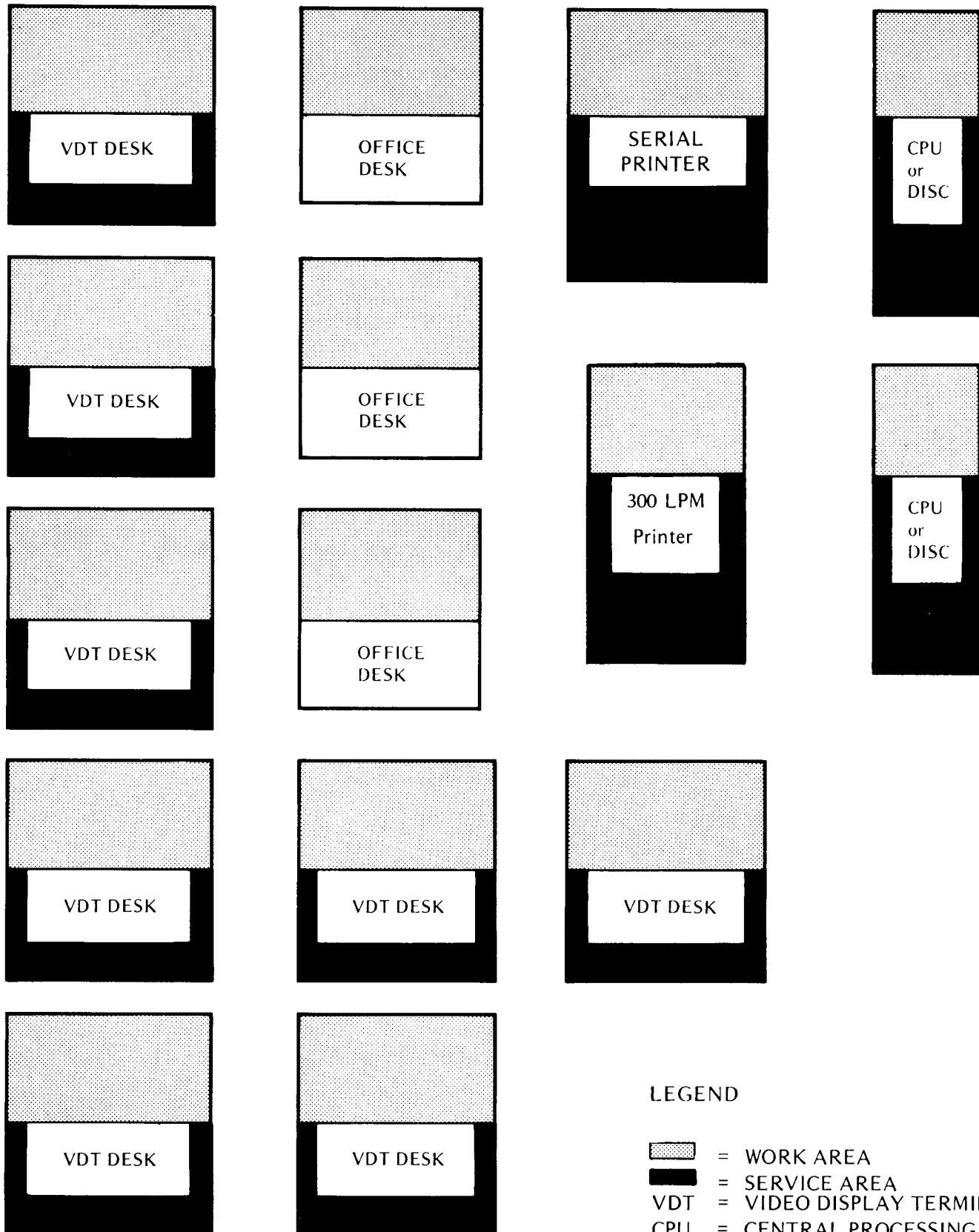
Equipment Line Drawings



LEGEND

-  = WORK AREA
-  = SERVICE AREA
- VDT = VIDEO DISPLAY TERMINAL
- CPU = CENTRAL PROCESSING CABINET
- DISC = DISC MEMORY CABINET

Scale: 3/16 in. = 1 ft.

Typical Floor Plans

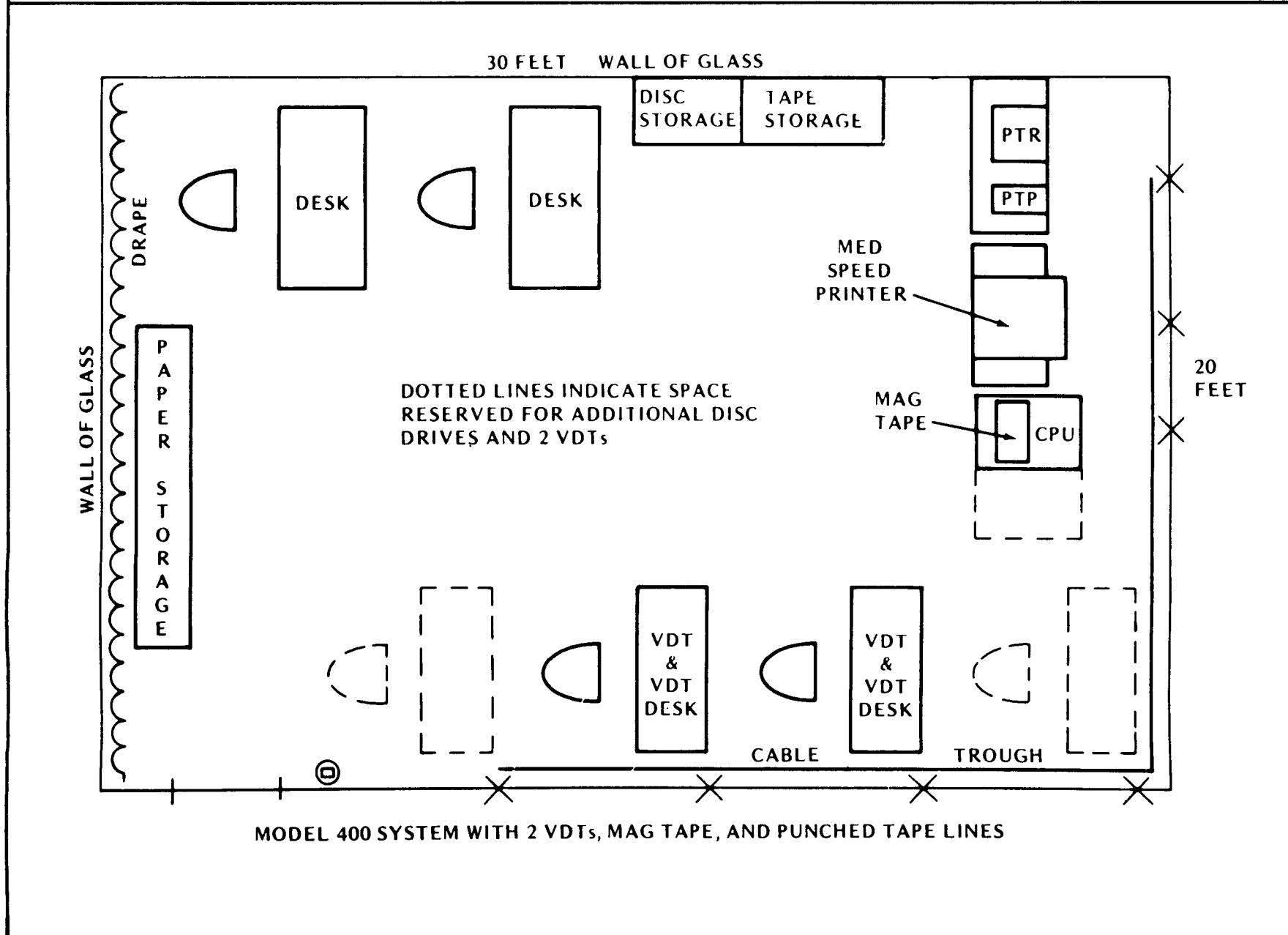
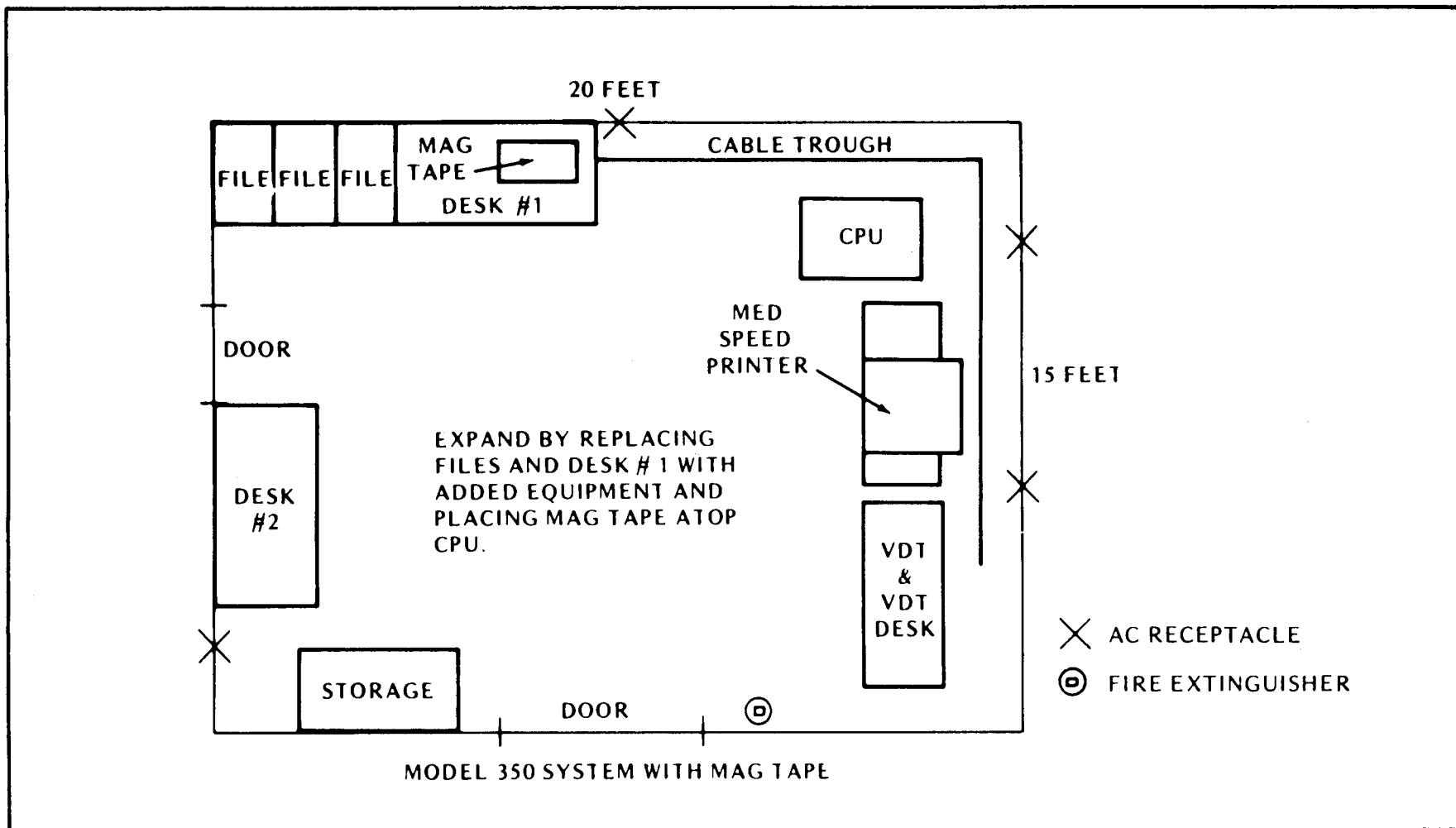

Preinstallation Checklist

	YES	NO	NOT APPLICABLE
ENVIRONMENT			
Thermostatically controlled heating installed.	<input type="checkbox"/>	<input type="checkbox"/>	<input type="checkbox"/>
Air conditioning installed (if req.).	<input type="checkbox"/>	<input type="checkbox"/>	<input type="checkbox"/>
Air conditioning rebalanced (if req.).	<input type="checkbox"/>	<input type="checkbox"/>	<input type="checkbox"/>
Dehumidifier installed (if req.).	<input type="checkbox"/>	<input type="checkbox"/>	<input type="checkbox"/>
Air filters installed in heating, ventilating and/or air conditioning units.	<input type="checkbox"/>	<input type="checkbox"/>	<input type="checkbox"/>
Electrostatic filter installed (if req.).	<input type="checkbox"/>	<input type="checkbox"/>	<input type="checkbox"/>
ELECTRICAL			
Power line noise problems resolved (if req.).	<input type="checkbox"/>	<input type="checkbox"/>	<input type="checkbox"/>
Lines installed for system, air conditioner, dehumidifier, and electrostatic filter (as req.).	<input type="checkbox"/>	<input type="checkbox"/>	<input type="checkbox"/>
Receptacles installed for above and/or for equipment removed from system line (as req.).	<input type="checkbox"/>	<input type="checkbox"/>	<input type="checkbox"/>
Lighting fixtures and switches or controls installed (if req.).	<input type="checkbox"/>	<input type="checkbox"/>	<input type="checkbox"/>
Power cables acquired (as req.).	<input type="checkbox"/>	<input type="checkbox"/>	<input type="checkbox"/>
Cable trough acquired (as req.).	<input type="checkbox"/>	<input type="checkbox"/>	<input type="checkbox"/>
LAYOUT			
Space allocated for system; non-system equipment; and associated desks, files, storage cabinets, etc.	<input type="checkbox"/>	<input type="checkbox"/>	<input type="checkbox"/>
Cable routing defined and extra length cables ordered.	<input type="checkbox"/>	<input type="checkbox"/>	<input type="checkbox"/>
Equipment positions established for proper lighting and power accessibility.	<input type="checkbox"/>	<input type="checkbox"/>	<input type="checkbox"/>
FIRE PREVENTION			
Overhead sprinklers installed (if req.).	<input type="checkbox"/>	<input type="checkbox"/>	<input type="checkbox"/>
Fire extinguishers installed.	<input type="checkbox"/>	<input type="checkbox"/>	<input type="checkbox"/>
Fire resistant files and cabinets acquired for flammable material.	<input type="checkbox"/>	<input type="checkbox"/>	<input type="checkbox"/>
MISCELLANEOUS			
Windows draped and/or treated with glass tinting.	<input type="checkbox"/>	<input type="checkbox"/>	<input type="checkbox"/>
Carpeting installed or existing carpeting treated with nonstatic fluid.	<input type="checkbox"/>	<input type="checkbox"/>	<input type="checkbox"/>
Telephone services installed.	<input type="checkbox"/>	<input type="checkbox"/>	<input type="checkbox"/>

NOTES

PAGE 16	TITLE Installation Planning Guide	DATE 6/14/76
-------------------	---	------------------------

Central Processor Cabinet



SPECIFICATIONS

Dimensions

Width	23 In.	(58 cm)
Depth	33½ In.	(85 cm)
Height	50 In.	(127 cm)

Service Clearances

Front	36 In.	(91.4 cm)
Rear	30 In.	(76.2 cm)
Sides	6 In.	(15.2 cm)

Weight

445 Lbs. (with single drive)	(202.27 Kilograms)
535 Lbs. (with dual drive)	(243.18 Kilograms)

Heat Output/Hr.

2000 Btu. (with single drive)
2700 Btu. (with dual drive)

Electrical

Voltage	115 ± 10% VAC or 230 ± 10%
Frequency	60 ± ½ Hz. or 50 ± ½ Hz.
Phases	Single

Power with single drive in CPU cabinet

Volt Amperes	565 (operating)
(Surge current = 18 amperes for 6 seconds)	

Power with two drives in CPU cabinet

Volt Amperes	225 (total 790, operating)
(Surge current = 15 amperes for 6 seconds for second drive)	

Environment

Temperature	60–90° F. (15–32°C)
Humidity	20–85% relative

Cable Lengths

Power	10 Ft. (3.05 meters)
Signal	(See peripheral specs)

PLAN VIEW

½ in. = 1 ft.

S = Signal Connector
P = Power Connector

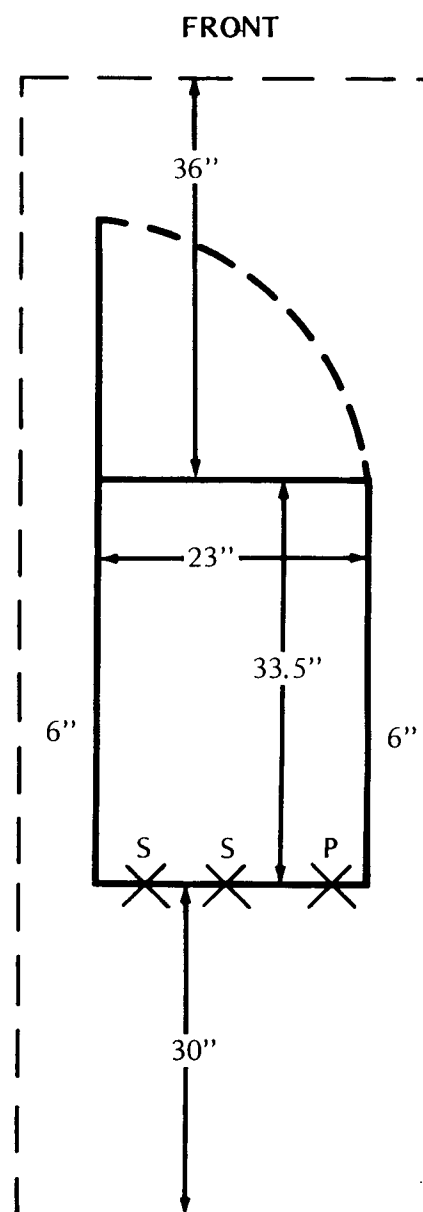

DATE 6/14/76	TITLE Installation Planning Guide	PAGE 17
-----------------	--------------------------------------	------------

Disc Memory Cabinet



SPECIFICATIONS

Dimensions

Width	23 In.	(58 cm)
Depth	33½ In.	(85 cm)
Height	50 In.	(127 cm)

Service Clearances

Front	36 In.	(91.4 cm)
Rear	30 In.	(76.2 cm)
Sides	6 In.	(15.2 cm)

Weight

425 Lbs. (single drive)	(238.64 Kilograms)
515 Lbs. (dual drive)	(234.09 Kilograms)

Heat Output/Hr.

700 Btu. (per drive)

Electrical

Voltage	115 ± 10% or 230 ± 10%
Frequency	60 ± ½ Hz. or 50 ± ½ Hz.
Phases	1
Volt Amperes	225 (per drive)
(Surge current per drive = 15 amperes for 6 seconds)	

Environment

Temperature	60–90°F. (15–32°C)
Humidity	20–85% relative

Cable Lengths

Power	10 Ft. (3.05 meters)
Signal	5 Ft. (1.52 meters)

PLAN VIEW

½ in. = 1 ft.

S = Signal Connector
P = Power Connector

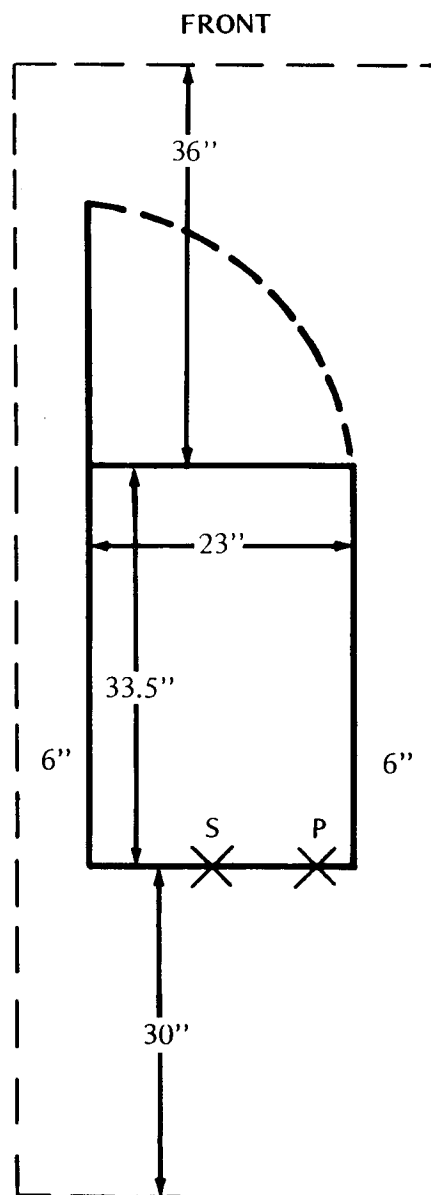

Video Display Terminal Model 7220/7230

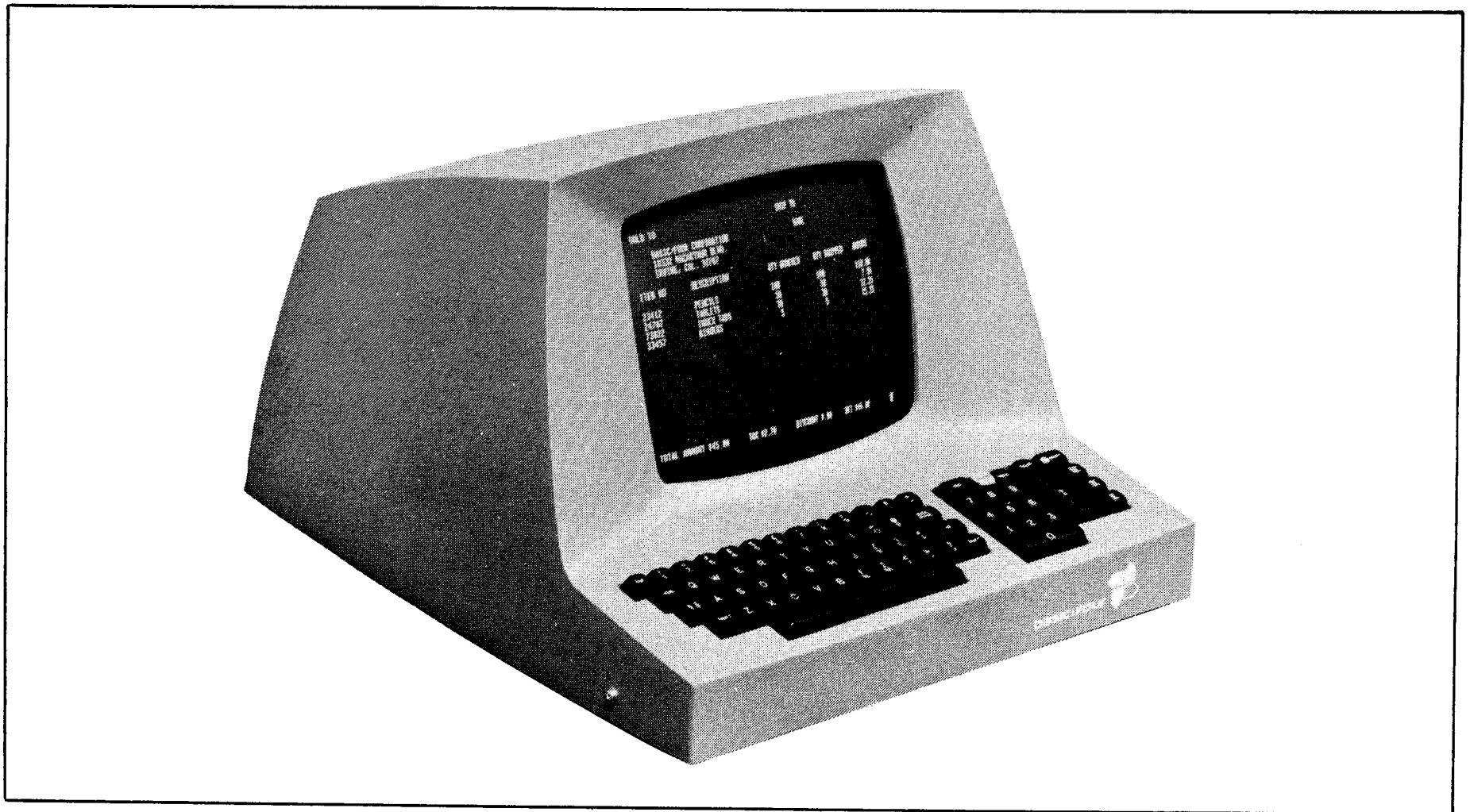

SPECIFICATIONS

Dimensions (without desk)

Width	17½ In. (44.4 cm)
Depth	21 In. (with keyboard) (53.3 cm)
Height	12 In. (30.4 cm)

Service Clearances

Front	36 In. (91.4 cm)
Rear	12 In. (30.4 cm)
Sides	6 In. (15.2 cm)

Weight 45 Lbs. (without desk) (20.45 Kilograms)

Heat Output/Hr. 825 Btu.

Electrical

Voltage	115 ± 10% or 230 ± 10%
Frequency	60 ± ½ Hz. or 50 ± ½ Hz.
Phases	1
Volt Amperes	230

Environment

Temperature	60 – 90°F. (15 – 32°C)
Humidity	20 – 85% relative

Cable Lengths

Power	7 Ft. (2.13 meters)
Signal	25 Ft. (7.62 meters)

PLAN VIEW (without desk) ½ in. = 1 ft.

S = Signal
Connector
P = Power
Connector

FRONT

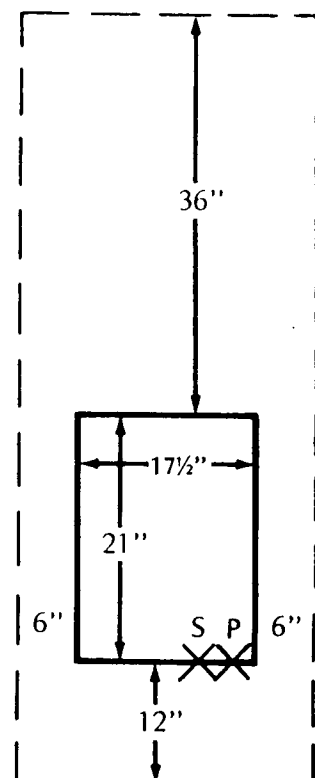

VDT Desk



SPECIFICATIONS

PLAN VIEW
1/2 in. = 1 ft.

FRONT

Dimensions	
Width	54 In. (137 cm)
Depth	24 ³ / ₄ In. (62.8 cm) (36 In. with VDT drop leaf 91.4 cm)
Height	28 In. (71.1 cm)
Service Clearances	
Front	36 In. (91.4 cm)
Rear	12 In. (30.4 cm)
Sides	6 In. (15.2 cm)
Weight	105 Lbs. (47.73 Kilograms)

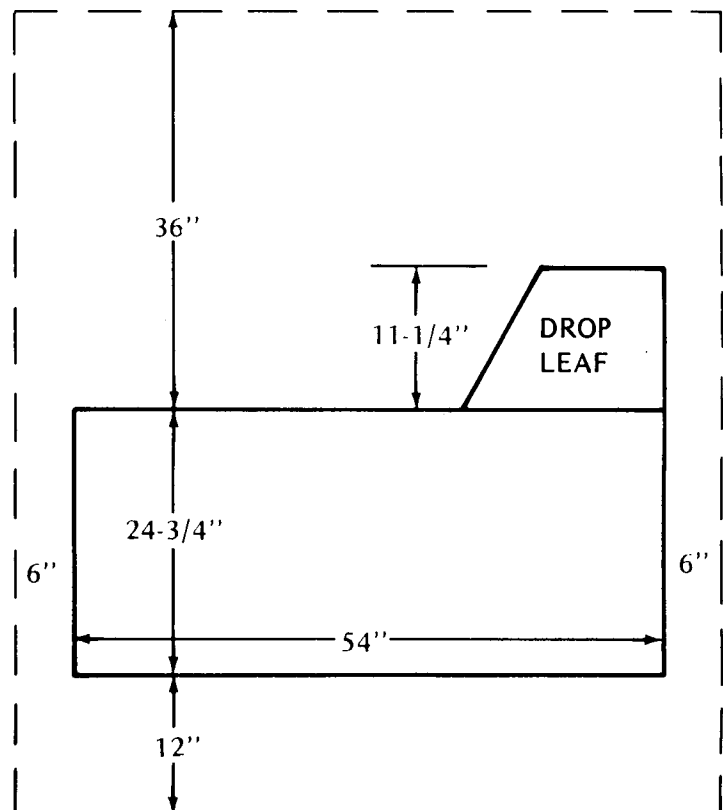

Executive Display Terminal

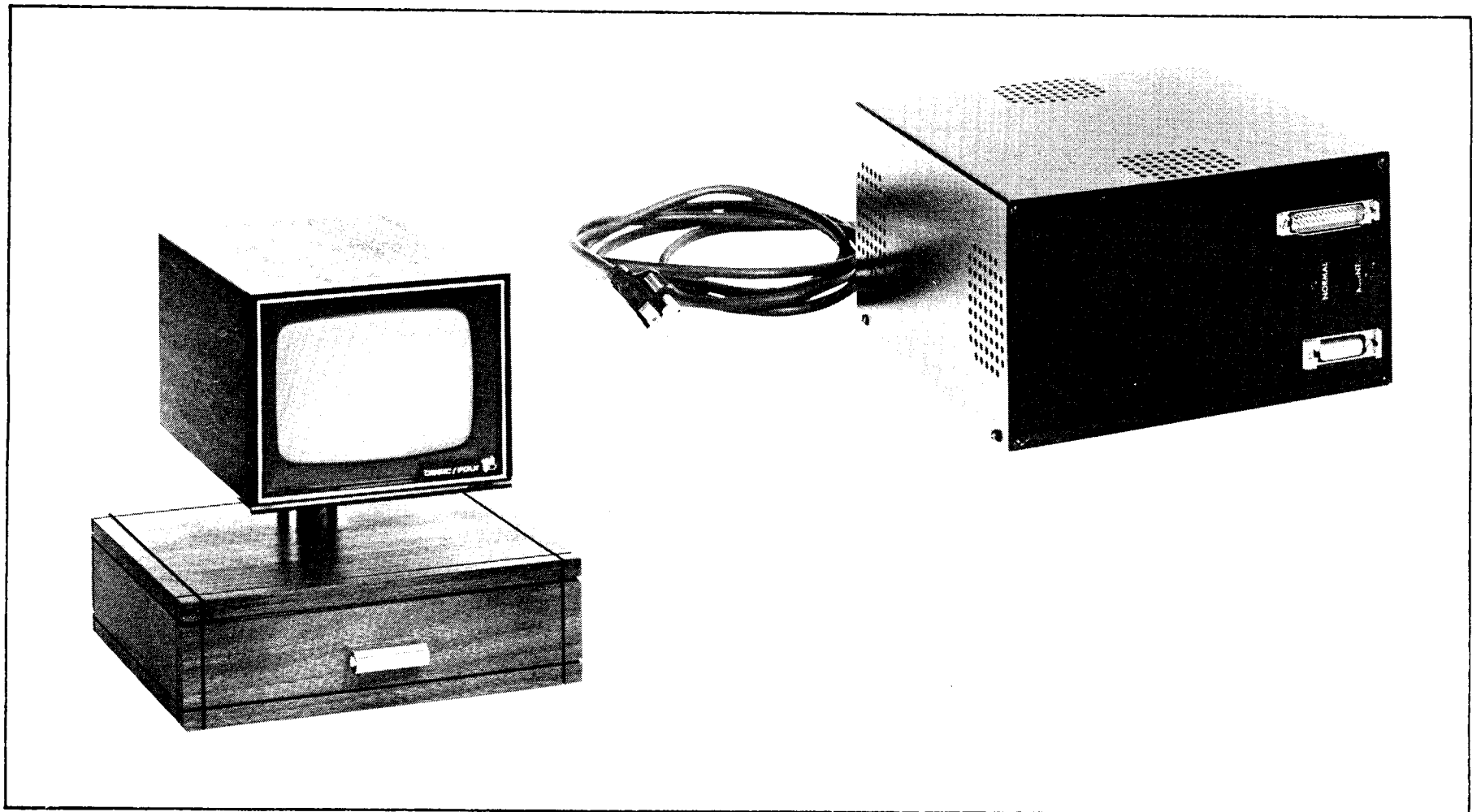

SPECIFICATIONS

Dimensions

Console

Width 10 In. (25.4 cm)
 Depth 12 In. (30.4 cm)
 (Keyboard Extended)
 Height 10 In. (25.4 cm)

Control Unit

8 In. (20.3 cm)
 8 In. (20.3 cm)
 4½ In. (11.4 cm)

Cable Lengths

Power 7½ Ft. (from control unit) (2.29 meters)
 Signal 15 Ft. (to console) (4.57 meters)
 Signal 25 Ft. (to CPU) (7.62 meters)

Service Clearances

Console

Front NA
 Rear NA
 Sides NA

Control Unit

10 In. (25.4 cm)
 4 In. (10.1 cm)
 4 In. (10.1 cm)

Weight

Console

11 lbs. (5 Kilograms)

Control Unit

8 lbs. (3.64 Kilograms)

Heat Output/Hr. 327 BTU

Electrical

Voltage 115±10% or 230 ± 10%
 Frequency 60±½ Hz. or 50 ± ½ Hz.
 Phases 1
 Volt Ampere 86

Environment

Temperature 60°–90° (15–32°C)
 Humidity 20–85% relative

CONSOLE

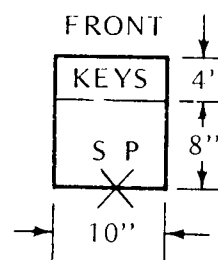

S = Signal Connector
 P = Power Connector

PLAN VIEW
 1/2 in = 1 ft.

CONTROL UNIT

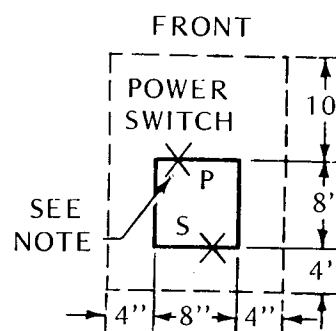

NOTE: BASE PLATE HAS 0.188 IN. MOUNTING HOLES 6 IN. ON CENTER.

DATE 6/14/76	TITLE Installation Planning Guide	PAGE 21
-----------------	--------------------------------------	------------

Serial Printer

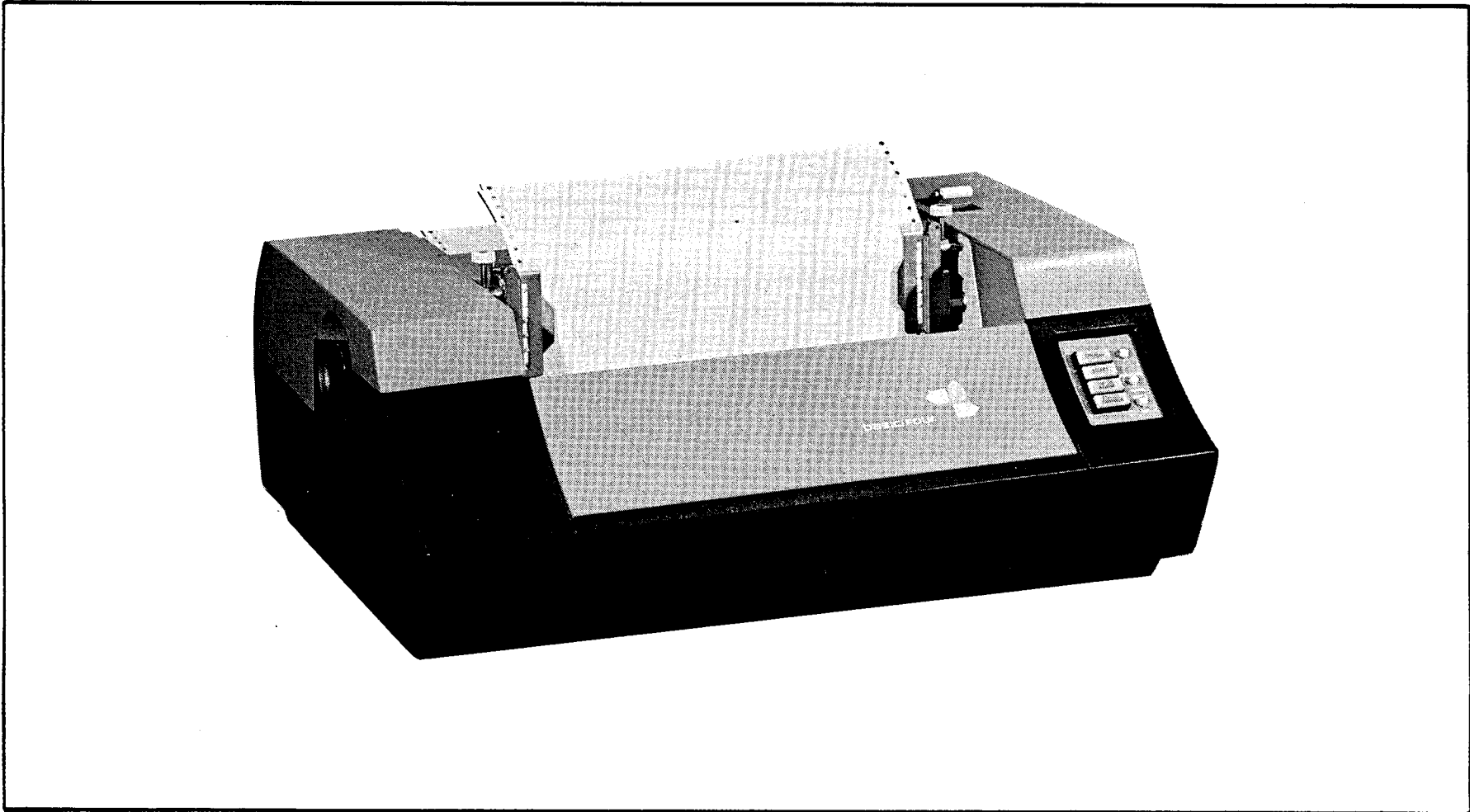

SPECIFICATIONS

Dimensions	Printer	Desk
Width	27½ In. (69.8 cm)	54 In. (137 cm)
Depth	19¼ In. (48.9 cm)	24¾ In. (62.8 cm)
Height	11¼ In. (28.5 cm)	28 In. (71.1 cm)
Service Clearances		
Front	36 In. (91.4 cm)	
Rear	30 In. (76.2 cm)	
Sides	6 In. (15.2 cm)	
Weight		
	144 Lbs. (without desk) (65.45 Kilograms)	
	244 Lbs. (with desk) (110.91 Kilograms)	
Heat Output/Hr. 1700 Btu.		
Electrical		
Voltage	115 ± 10% or 230 ± 10%	
Frequency	60 ± ½ Hz. or 50 ± ½ Hz.	
Phases	1	
Volt Amperes	450	
Environment		
Temperature	60 - 90°F. (15 - 32°C)	
Humidity	20 - 85% relative	
Cable Lengths		
Power	7 Ft. (2.13 meters)	
Signal	15 Ft. (2.44 meters)	

PLAN VIEW

1/2 in. = 1 ft.

S = Signal Connector
P = Power Connector

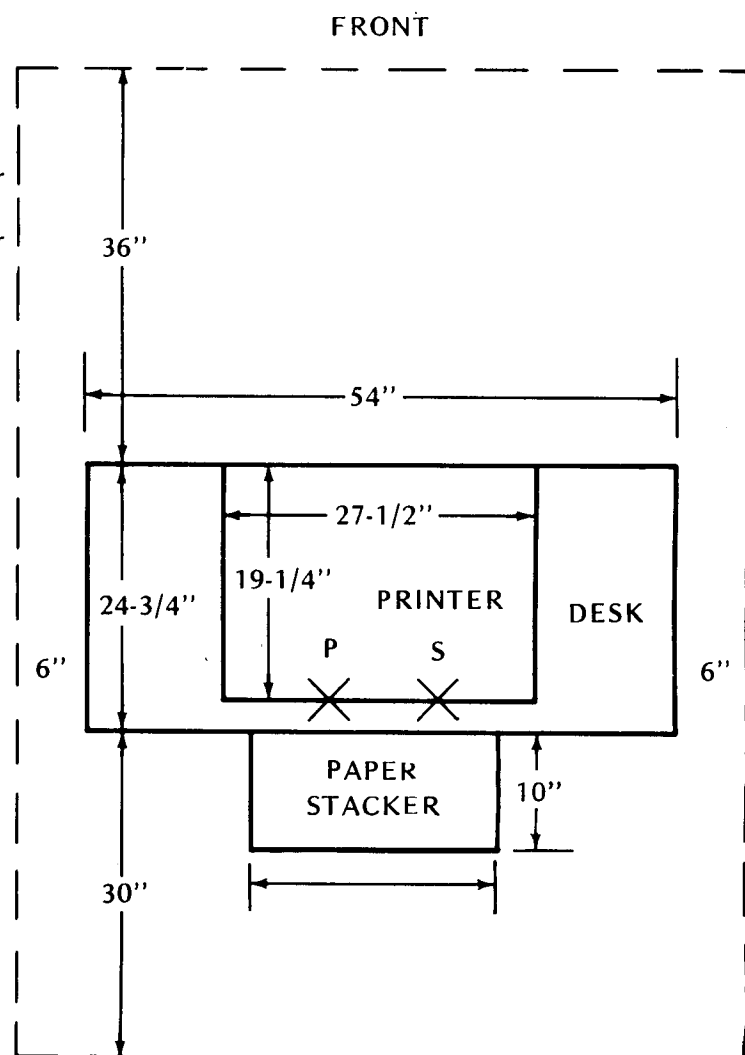

300 LPM Printer Model 3500



SPECIFICATIONS

Dimensions	
Width	33 inches (83.8 cm)
Depth	22 inches (55.9 cm)
Height	45 inches (114.3 cm)
Service Clearances	
Front	36 inches (91.4 cm)
Rear	22 inches (55.8 cm)
Right Side	6 inches (15.2 cm)
Left Side	17 inches (43.1 cm)
Weight	340 lbs (153 kilograms)
Heat Output/Hr.	1800 BTU/Hr. Nominal
Electrical	
Voltage	115 or 230 $\pm 10\%$
Frequency	60 or 50 Hertz $\pm 2\%$
Phases	Single phase
Volt Amperes	525
Environment	
Temperature	60 to 90°F (15–32°C)
Humidity	30 to 90% (noncondensing)
Cable Length	
Power	12 ft (3.66 meters)
Signal	15 ft (4.57 meters)

PLAN VIEW
1/2 in. = 1 ft

S = Signal
Connector
P = Power
Connector

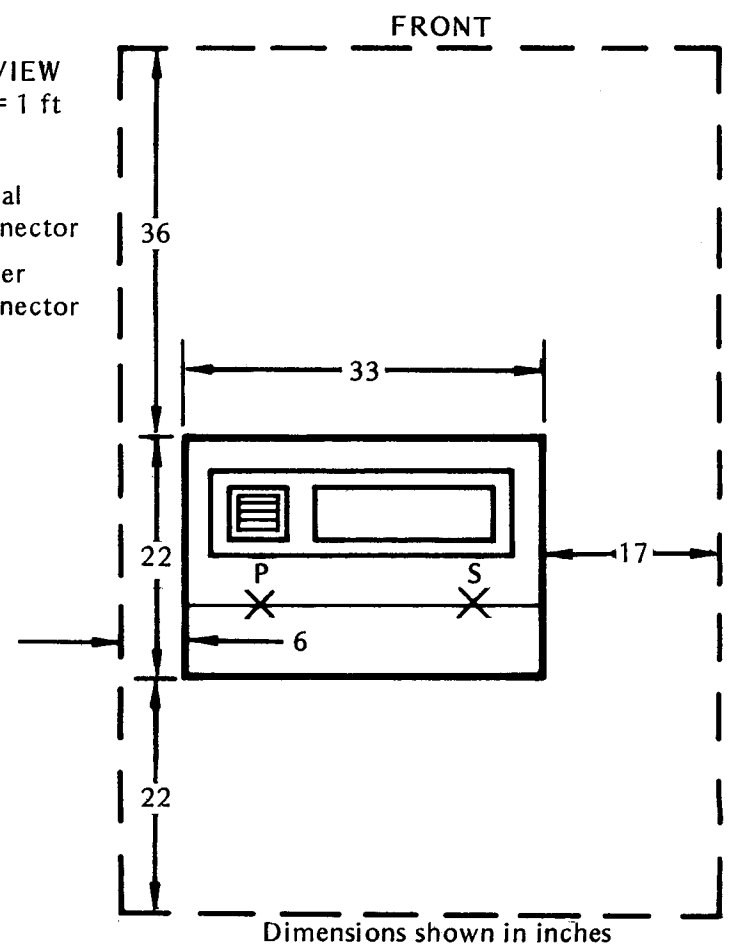

600 LPM Printer Model 3600



SPECIFICATIONS

Dimensions

Width	33 inches (83.8 cm)
Depth	26 inches (66 cm)
Height	44.5 inches (113 cm)

Service Clearances

Front	36 inches (91.4 cm)
Rear	22 inches (55.8 cm)
Right Side	6 inches (15.2 cm)
Left Side	17 inches (43.1 cm)

Weight

370 lbs (166.5 kilograms)

Heat Output/Hr.

2335 BTU/Hr. Nominal

Electrical

Voltage	115 or 230 \pm 10%
Frequency	60 or 50 Hertz \pm 2%
Phases	Single phase
Volt Amperes	680

Environment

Temperature	60 to 90°F (15–32°C)
Humidity	30 to 90% (noncondensing)

Cable Lengths

Power	12 ft (3.66 meters)
Signal	15 ft (2.44 meters)

PLAN VIEW 1/2 in. = 1 ft

S = Signal
Connector
P = Power
Connector

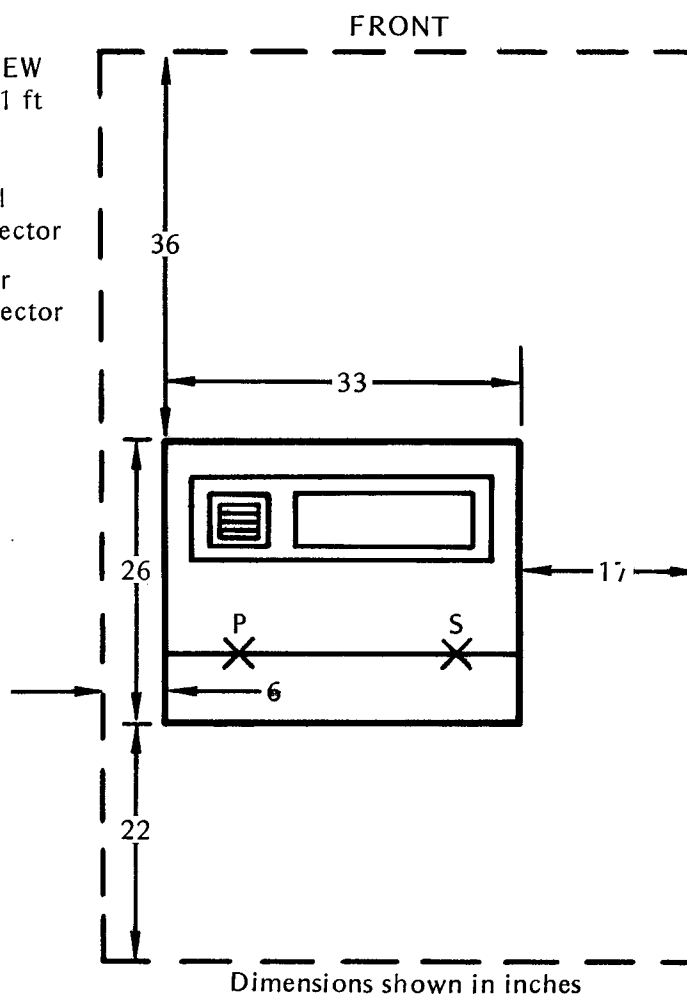

Punched Card Reader

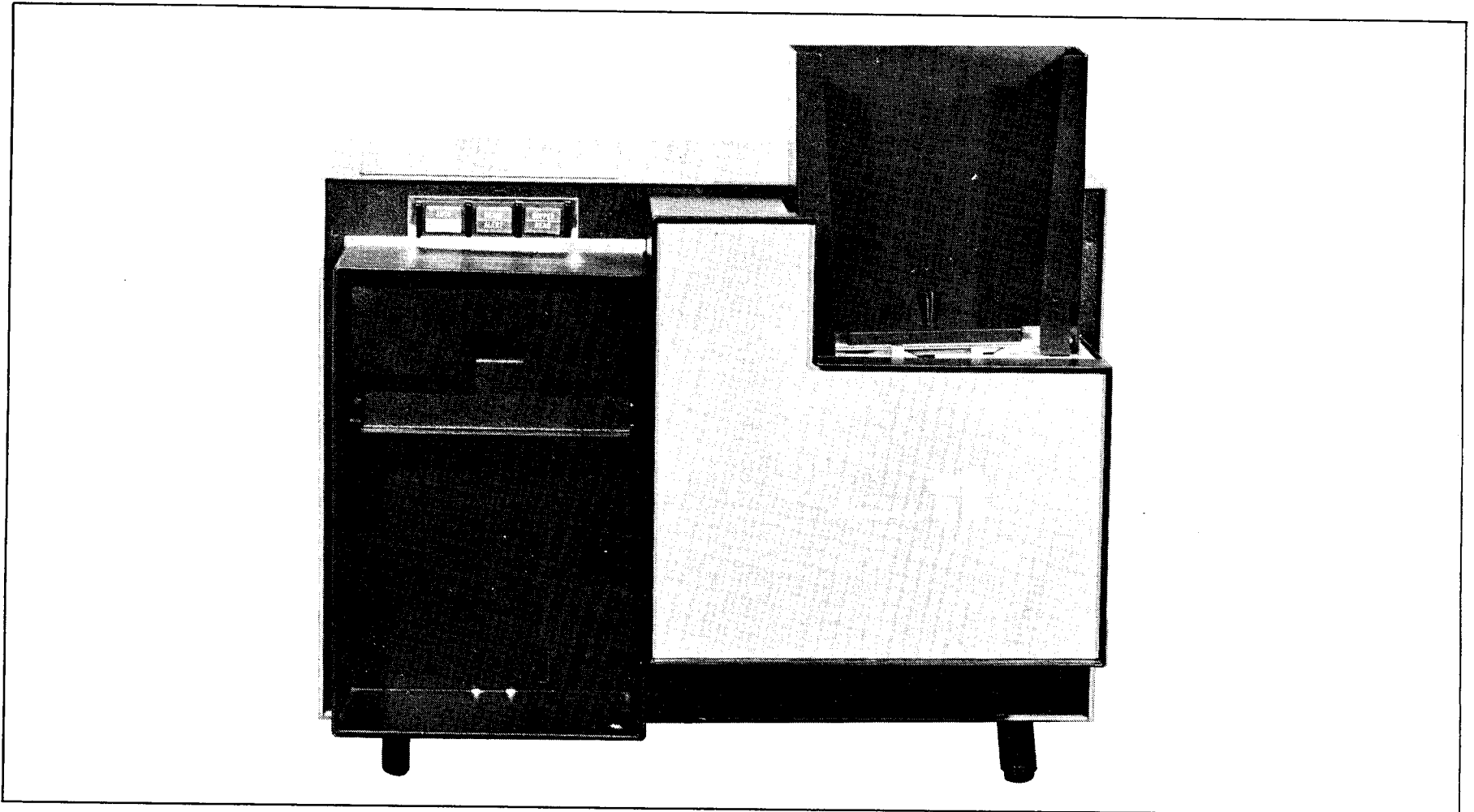

SPECIFICATIONS

Dimensions

Width	21½ In.	(54.6 cm)
Depth	18 In.	(45.7 cm)
Height	20½ In.	(52 cm)

Service Clearances

Front	36 In.	(91.4 cm)
Rear	12 In.	(30.4 cm)
Sides	6 In.	(15.2 cm)

Weight

89 Lbs. (40.45 Kilograms)

Heat Output/Hr.

1100 Btu.

Electrical

Voltage	115 ± 10% or 230 ± 10%
Frequency	60 ± ½ Hz. or 50 ± ½ Hz.
Phases	1
Volt Amperes	230

Environment

Temperature	60 - 90°F. (15 - 32°C)
Humidity	20 - 85% relative

Cable Lengths

Power	7 Ft. (2.13 meters)
Signal	15 Ft. (4.57 meters)

PLAN VIEW 1/2 in. = 1 ft.

S = Signal
Connector
P = Power
Connector

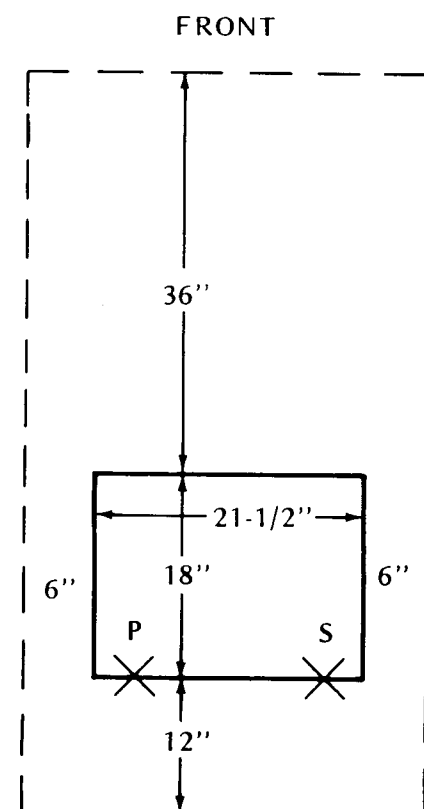

Magnetic Tape Unit

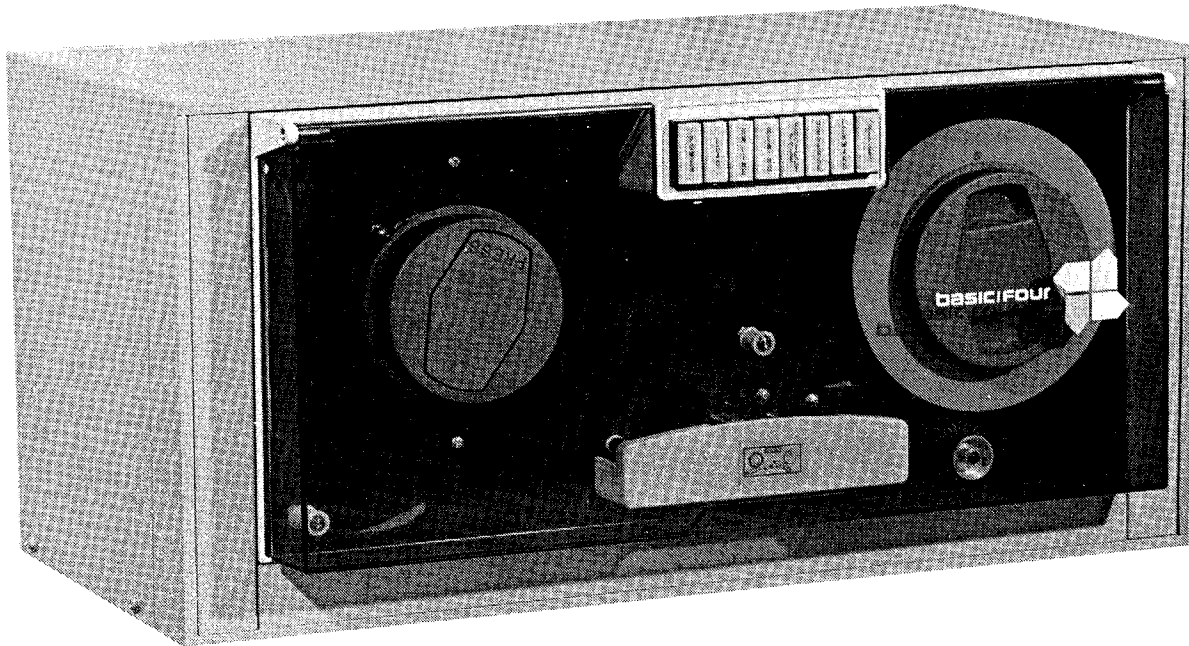

SPECIFICATIONS

Dimensions

Width	22 In. (55.8 cm)
Depth	12 In. (30.4 cm)
Height	10 ³ / ₄ In. (27.3 cm)

Service Clearances

Front	36 In. (91.4 cm)
Rear	12 In. (30.4 cm)
Sides	6 In. (15.2 cm)

Weight

65 Lbs. (29.55 Kilograms)

Heat Output/Hr.

350 Btu.

Electrical

Voltage	115 ± 10% or 230 ± 10%
Frequency	60 ± ½ Hz. or 50 ± ½ Hz.
Phases	1
Volt Amperes	115

Environment

Temperature	60 - 90°F. (15 - 32°C)
Humidity	20 - 85% relative

Cable Lengths

Power	7 Ft. (2.13 meters)
Signal	13 Ft. (3.96 meters)

PLAN VIEW

1/2 in. = 1 ft.

S = Signal
Connector
P = Power
Connector

FRONT

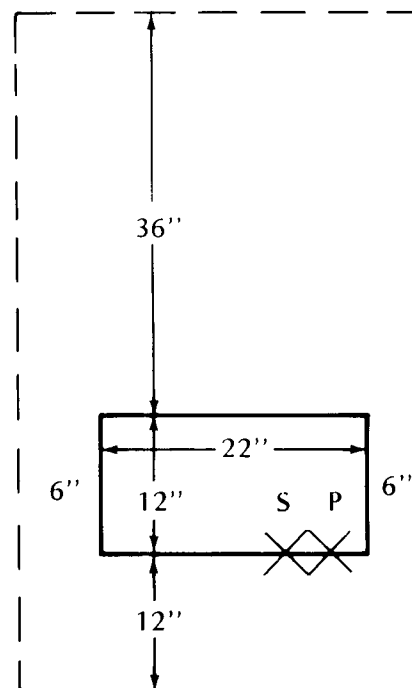

Paper Tape Punch

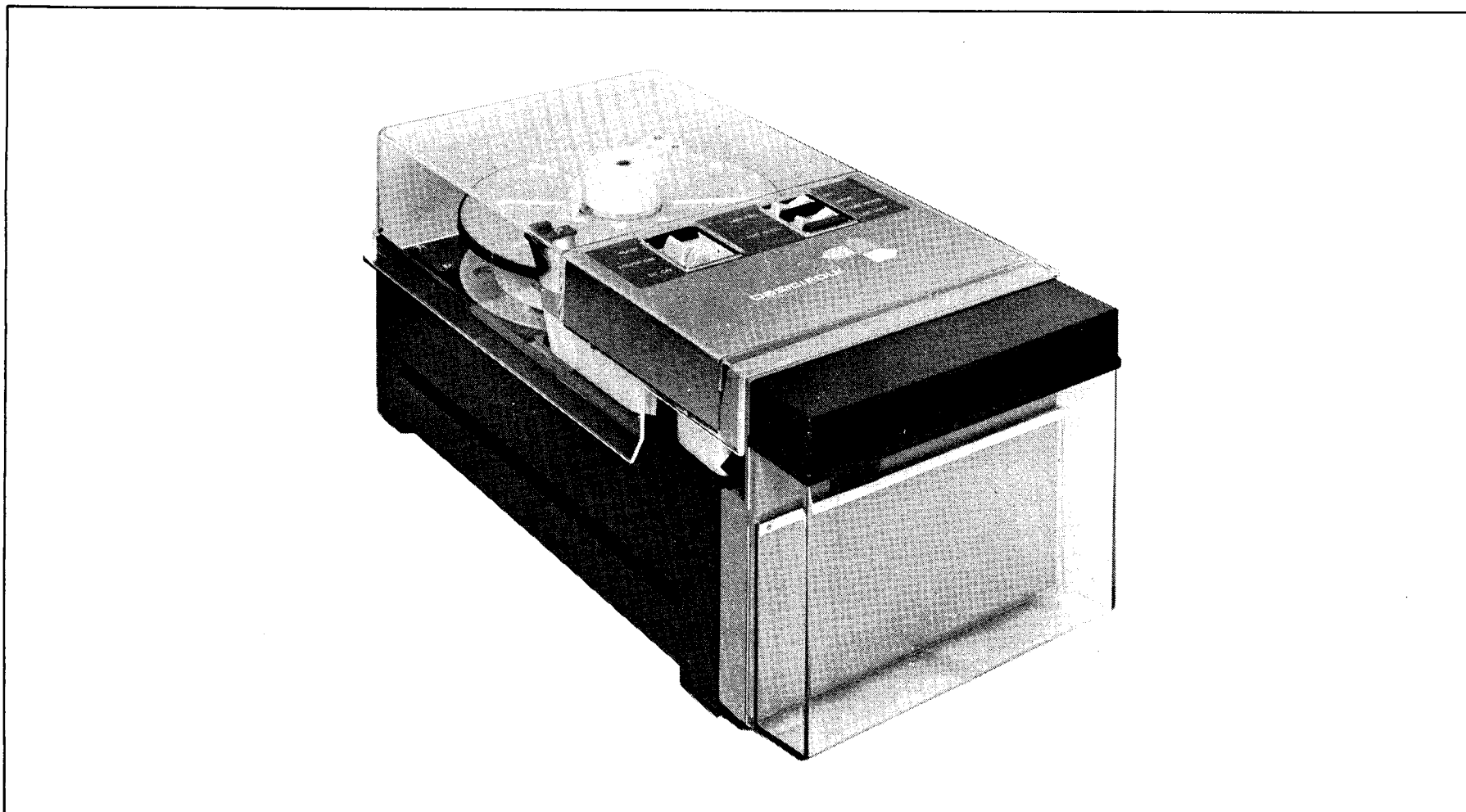

SPECIFICATIONS

Dimensions

Width	9½ In.	(24.1 cm)
Depth	19½ In.	(49.5 cm)
Height	7½ In.	(19 cm)

Service Clearances

Front	36 In.	(91.4 cm)
Rear	12 In.	(30.4 cm)
Sides	6 In.	(15.2 cm)

Weight

30 Lbs. (13.64 Kilograms)

Heat Output/Hr.

700 Btu.

Electrical

Voltage	115 ± 10% or 230 ± 10%
Frequency	60 ± ½ Hz. or 50 ± ½ Hz.
Phases	1
Volt Amperes	200

Environment

Temperature	60 - 90°F. (15 - 32°C)
Humidity	20 - 85% relative

Cable Lengths

Power	7 Ft. (2.13 meters)
Signal	15 Ft. (4.57 meters)

PLAN VIEW 1/2 in. = 1 ft.

S = Signal
Connector
P = Power
Connector

FRONT

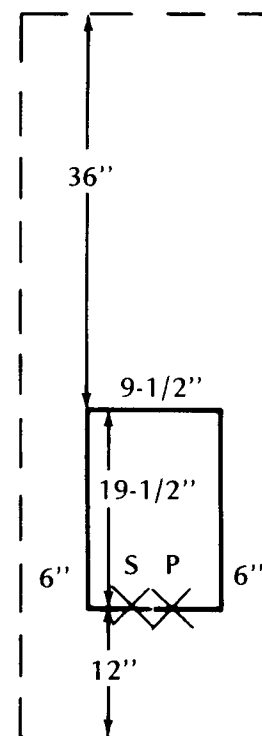

DATE

6/14/76

TITLE

Installation Planning Guide

PAGE

27

Paper Tape Reader

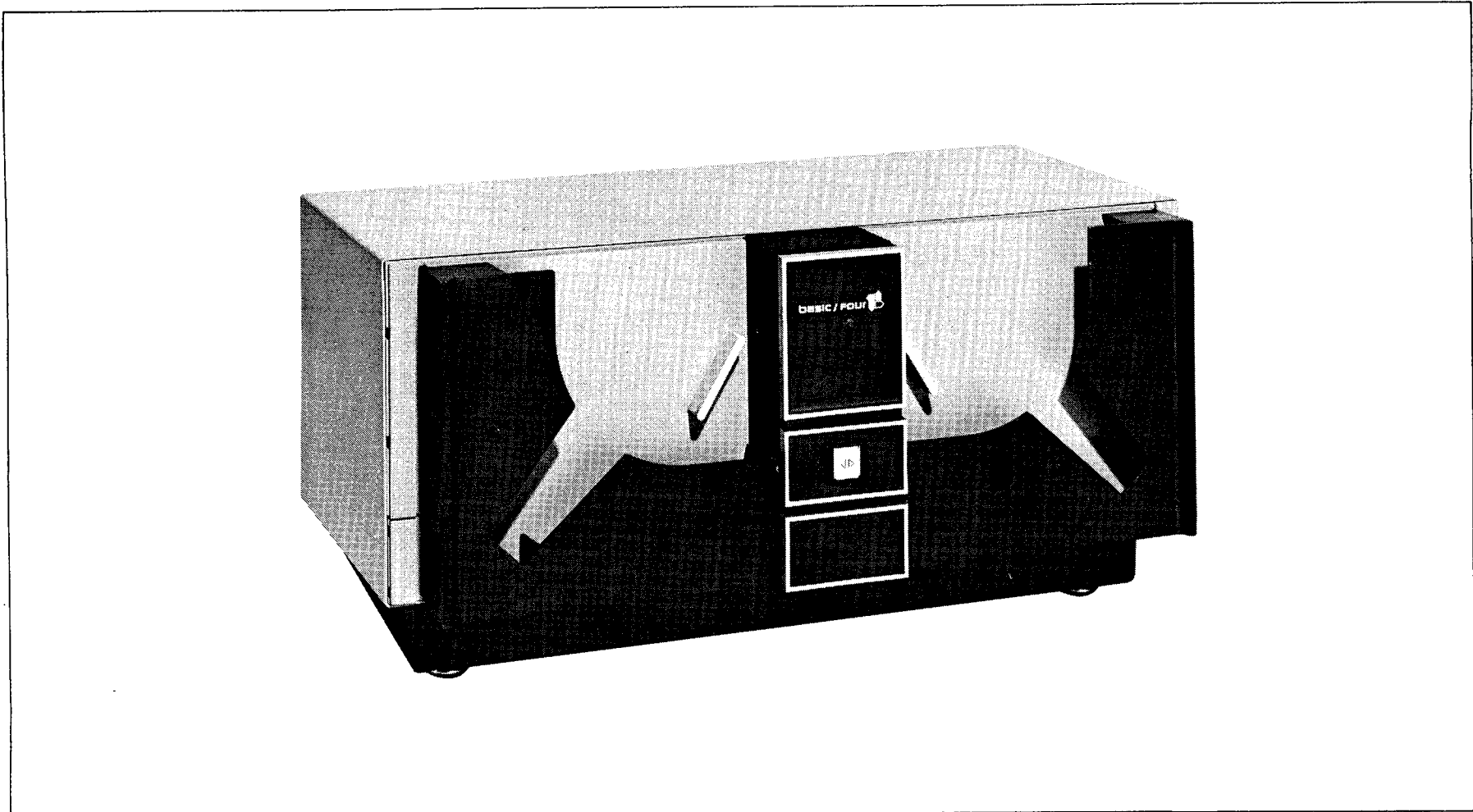

SPECIFICATIONS

Dimensions

Width	15 In. (38.1 cm)
Depth	15½ In. (39.3 cm)
Height	10 In. (25.4 cm)

Service Clearances

Front	36 In. (91.4 cm)
Rear	12 In. (30.4 cm)
Sides	6 In. (15.2 cm)

Weight

70 Lbs. (31.82 Kilograms)

Heat Output/Hr.

600 Btu.

Electrical

Voltage	115 ± 10% or 230 ± 10%
Frequency	60 ± ½ Hz. or 50 ± ½ Hz.
Phases	1
Volt Amperes	175

Environment

Temperature	60 - 90°F. (15 - 32°C)
Humidity	20 - 85% relative

Cable Lengths

Power	7 Ft. (2.13 meters)
Signal	15 Ft. (4.57 meters)

PLAN VIEW

1/2 in. = 1 ft.

S = Signal
Connector
P = Power
Connector

FRONT

